

Service Manual

Altronic V^{NG} Ignition System

Small Engines, 2-6 Cylinders

Form AV-NG SM 06-22

altronic



TABLE OF CONTENTS

SECTION	ITEM	PAGE
1.0	SYSTEM DESCRIPTION	3
2.0	PARTS IDENTIFICATION AND SPECIFICATION	4
2.1	Parts List	5-6
2.2	Part Number Designation	6
2.3	Unit Specifications	7
3.0	PERFORMANCE SPECIFICATIONS	7
3.1	Voltage Test	7
3.2	Operating Test	7
3.3	Timing Specifications	7
4.0	TROUBLESHOOTING	8
4.1	Oscilloscope Testing	8
4.2	Procedure	9
4.3	One Output Does Not Fire	9
4.4	System Has Weak or No Output	9
5.0	SERVICE – ALTERNATOR SECTION	9
5.1	Disassembly	9
5.2	Parts Replacement	9
5.3	Reassembly	10
6.0	SERVICE – BACK COVER ASSEMBLY	11
6.1	Circuit Board Assembly Replacement	11
6.2	Driven Gear/Magnet Arm Assembly	11
6.3	Driven Shaft, Bearing	11
6.4	Reassembly -Back Cover to Alternator	11
7.0	SERVICE – ASSEMBLY TOOLS	13
8.0	OPERATIONAL TEST	13

IMPORTANT SAFETY NOTICE:
PROPER INSTALLATION, MAINTENANCE, REPAIR AND OPERATION OF THIS EQUIPMENT IS ESSENTIAL. THE RECOMMENDED PRACTICES CONTAINED HEREIN SHOULD BE FOLLOWED WITHOUT DEVIATION. AN IMPROPERLY INSTALLED OR OPERATING IGNITION SYSTEM COULD CAUSE PERSONAL INJURY TO OPERATORS OR OTHER NEARBY PERSONNEL.

1.0 ALTRONIC V^{NG} IGNITION SYSTEM – DESCRIPTION

Altronic V^{NG} is an alternator powered, electronic ignition system. All electronic parts are mounted to the back cover which disconnects as a module from the alternator section.

The alternator (A) provides the power to charge energy storage capacitor (B). A separate HE pickup (C) and IGBT (D) are used for each of the system's outputs which correspond usually to each engine cylinder. A rotating timer (E) driven through speed reducing gears (F) passes over the HE pickup to trigger on the IGBT switches in sequence. This releases the capacitor's stored energy to the ignition coils which step up the voltage to fire the spark plugs.

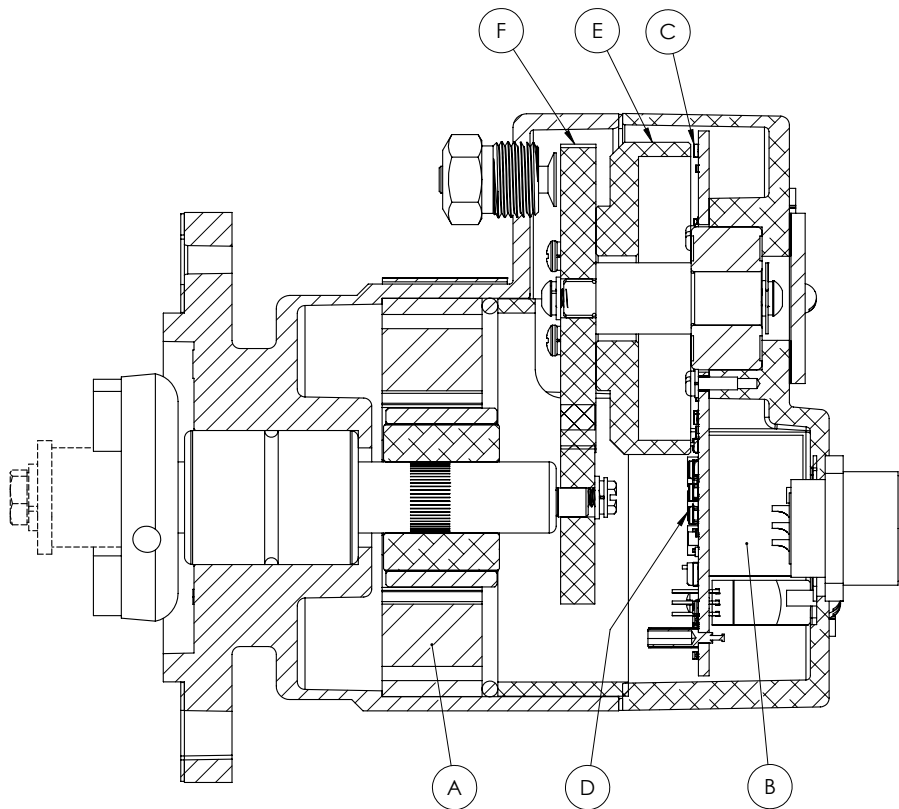

CROSS-SECTIONAL VIEW — ALTRONIC V^{NG} UNIT

- A – Alternator
- B – Energy Storage Capacitor
- C – HE Pickup
- D – IGBT Electronic Switch
- E – Timer
- F – Distribution Gears

2.0 PARTS IDENTIFICATION AND SPECIFICATION

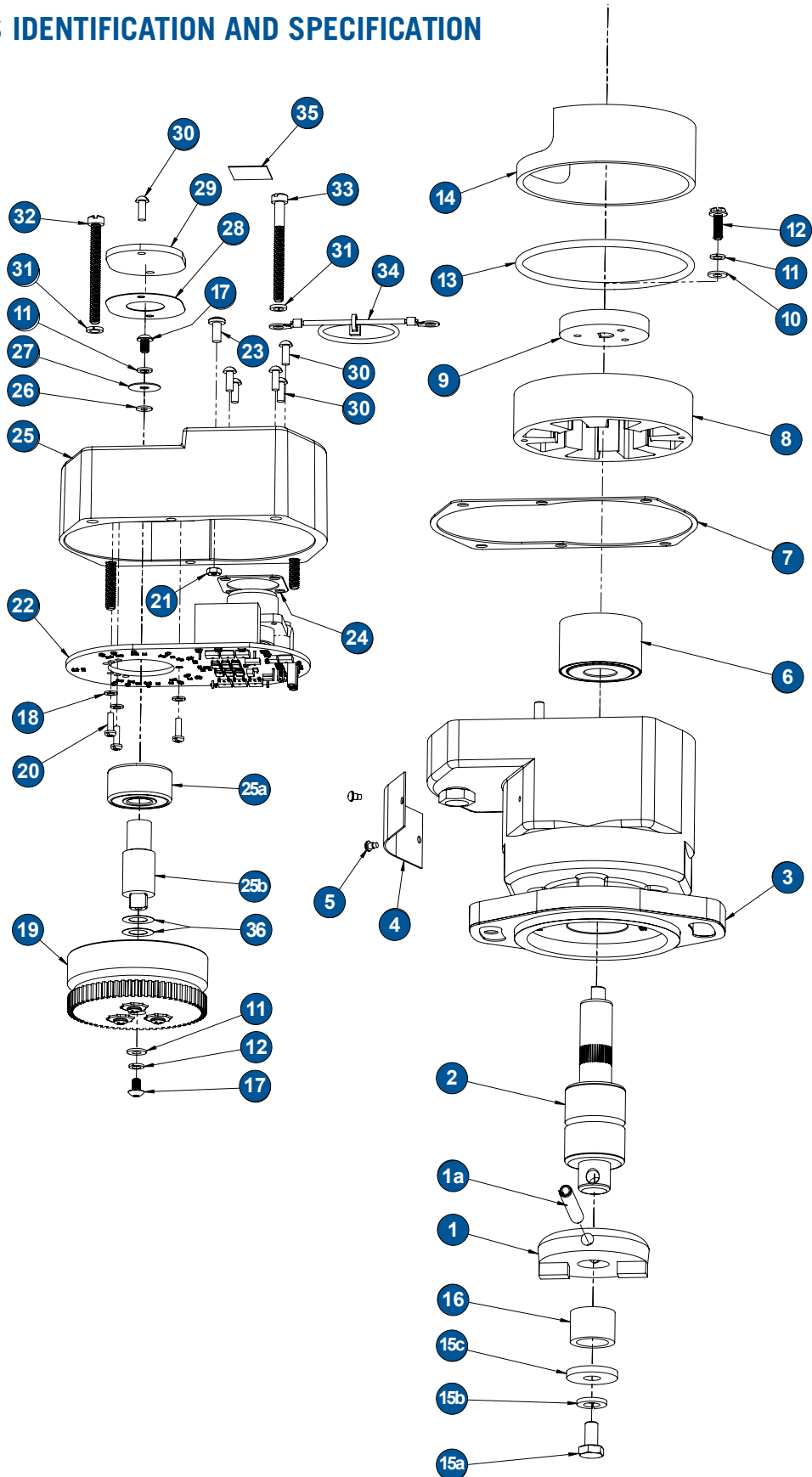

2.1 PARTS LIST – See exploded view, page 4.

Reference numbers with a letter suffix are part of an assembly of the same number without a suffix. Example: (1a) is part of (1).

REF. NO.	PART NO.	DESCRIPTION
1	510454-U	Coupling
	510699	Coupling
1a	902478	Spring pin, 2-1/8" lg.
2	410063	Bearing-shaft (-A, -AM, -D)
	510654	Bearing-shaft (-AW, -GVW)
3	560004-1	Housing (-A, -AM, -AW)
	560004-2	Housing (-GV, -GVW)
	560004-3	Housing (-D)
	560004-4	Housing (-GVC)
	560004-5	Housing (Caterpillar Unit)
	560004-6	Housing (DC)
4	502229	Nameplate - 3.5" X 1.1"
5	902520	Drive pin
6	560011	Magnet-rotor
7	410039	Gasket
8	571003	Stator
9	310518	Drive Gear 1.5:1
	510357	Drive Gear 2:1
	510359	Drive Gear 3:1
	510625	Drive Gear 1:1
10	901326	Washer
11	900944	Lockwasher, #8
12	902465	Screw, 8-32
13	510462	O-ring
14	410038	Spacer
15a	902585	Screw, 5/16"-18
15b	901010	Lockwasher, 5/16"
15c	902586	Washer
16	410045	Extended Shaft Bushing
17	902541	Screw, 8-32
18	14C-HC55	Lockwasher, #4

REF. NO.	PART NO.	DESCRIPTION
19	570410-1	Magnet holder gear 1:1
	570410-6	Magnet holder gear 1.5:1
	570410-2	Magnet holder gear 2:1
	570410-3	Magnet holder gear 3:1
20	901090	Screw, 4-40
21	901679	Nut, 8-32
22	580056-1	Circuit Board Assembly
	580056-2	Circuit Board Assembly 2
	580056-3	Circuit Board Assembly 3
	580056-4	Circuit Board Assembly 4
	580056-5	Circuit Board Assembly 5
	580056-6	Circuit Board Assembly 6
23	902834	8-32 x 3/16" screw
24	501335	Gasket, 5-pin connector
	501368	Gasket, 7-pin connector
25	570005	Rear cover, 5-pin conn.
	570028	Rear cover, 7-pin conn.
25a	410058	Bearing
25b	510660	Shaft, driven
26	902591	Washer
27	302106	Timing label, shaft
28	502226	Timing label, cover
29	310365	Plate cover
30	902064	Screw, 6-32
31	901004	Lockwasher, #10
32	902587	Screw, 10-24 x 2"
33	902483	Screw, 10-24 x 2-1/4"
34	501504	Wire Assembly, Ground
35	502233	Ground Warning Label
36	902579	Shim Washer (as needed)

2.2 PART NO. DESIGNATION

6 A 3 4 - A

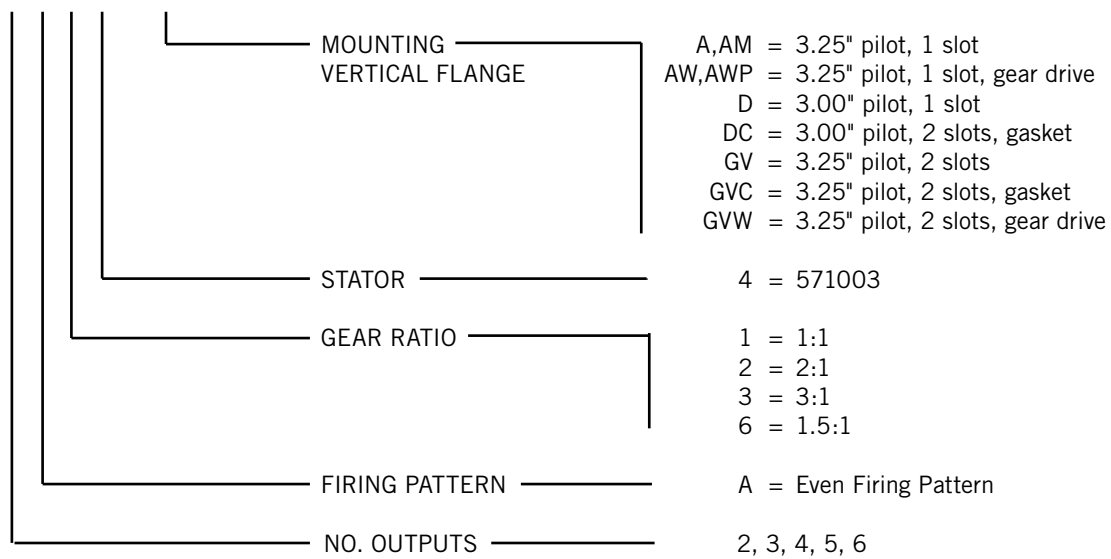

2.3 UNIT SPECIFICATIONS

UNIT NUMBER	BACK COVER	CIRCUIT BOARD
2A14	581409-4	580056-2
2A18	USE UNIT 2A14	
3A14	581409-9	580056-3
3A64	581409-8	580056-3
4A24	581409-12	580056-4
4A34	581409-13	580056-4
5A24	581409-7	580056-5
6A24	581409-17	580056-6
6A34	581409-15	580056-6

3.0 PERFORMANCE SPECIFICATIONS

Install unit on a test stand equipped with a suitable number of 501061 coils and spark gaps. Test stand wiring should conform to that shown in the Installation Instructions form AV-NG II.

3.1 VOLTAGE TEST

With the wiring harness unplugged, measure the positive voltage at the connector “G” or “E” pin. Voltage should be 150-210Vdc.

3.2 OPERATING TEST

- A. At 50 RPM of the back cover, a 7mm gap should fire consistently.
- B. At the TEST RPM, a 15mm gap should fire consistently.

3.3 TIMING SPECIFICATIONS

Timing should be as specified in the table below as measured on a standard ignition test stand with the degree wheel indicator rotating at the unit coupling speed.

3.3 TIMING SPECIFICATIONS

UNIT NO.	COUPLING TEST RPM	COUPLING ROTATION	FIRING SEQUENCE DEGREES						TOLERANCE ±
			A	B	C	D	E	F	
2A14	2,000	CW	0	180					2
3A14	2,000	CW	0	120	240				2
3A64	3,000	CW	0 180	0 180	0 180				3
4A24	2,000	CW	0	180	0	180			2
4A34	3,000	CW	0	270	180	90			3
5A24	2,000	CW	0	144	288	72	216		2
6A24	2,000	CW	0	120	240	0	120	240	2
6A34	3,000	CCW	0	180	0	180	0	180	3

4.0 TROUBLESHOOTING

4.1 OSCILLOSCOPE TESTING

The system should be fully connected per section 3.0 with the Altronic V unit operating at the TEST RPM given in section 3.3. Connect the oscilloscope probe to the shutdown lead of the output connector - "E" for the 5-pin connector or "G" for the 7-pin connector. Set the oscilloscope vertical calibration to 50 volts/div.; adjust the time base to get a full cycle of firings on the screen: No. of discharges = number of outputs for the unit.

- A. STORAGE CAPACITOR PATTERN: NORMAL - The normal patterns for typical 3-output (3A64) and 6-output (6A34) units are shown below.

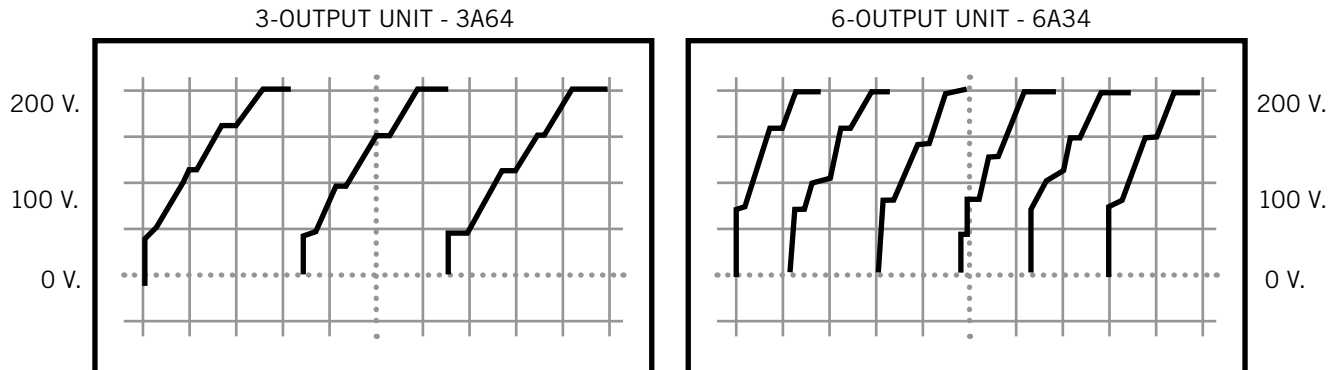

- B. STORAGE CAPACITOR PATTERN: ABNORMAL - One cylinder misfiring. See troubleshooting section 4.3.

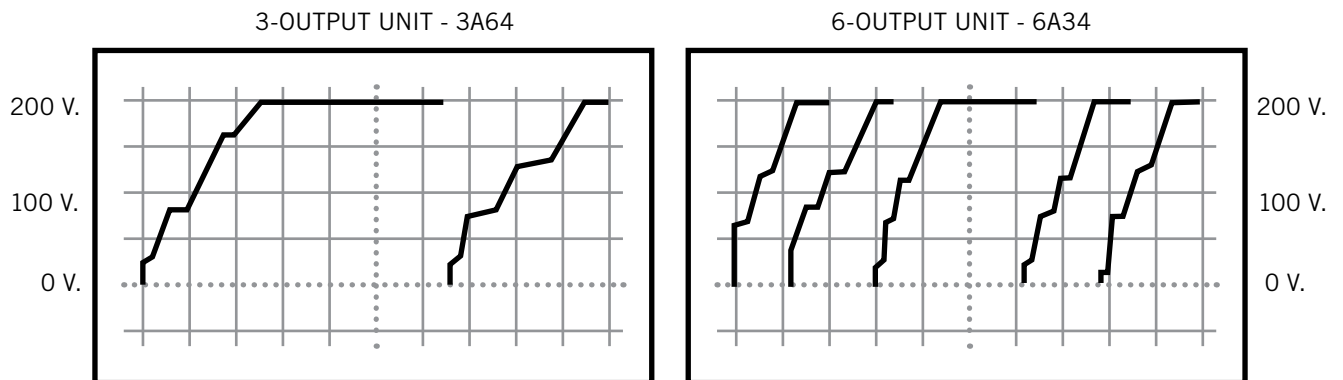

- C. STORAGE CAPACITOR PATTERN: ABNORMAL - Irregular waveform. See troubleshooting section 4.4.

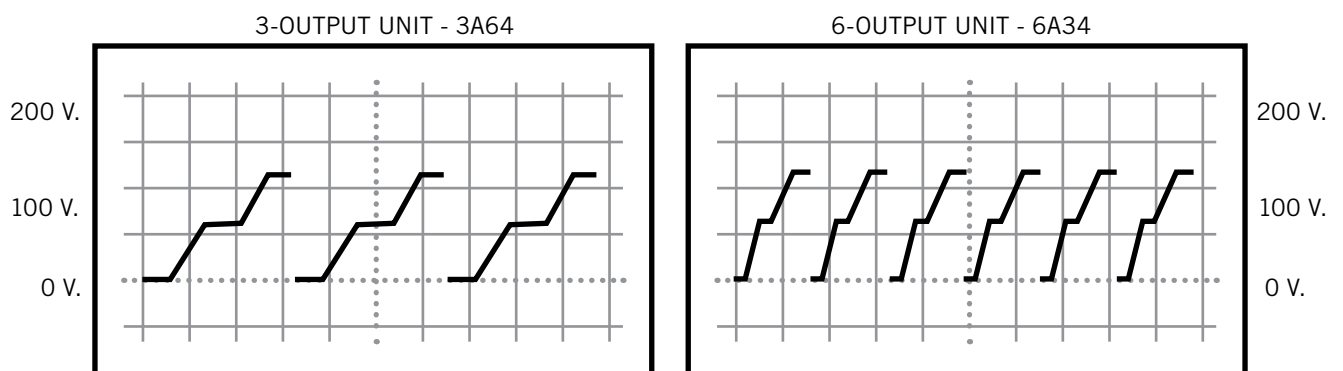

4.2 PROCEDURE

- A. See section 3.0-3.3 for proper performance.
- B. Use Simpson model 260 meter on RX10,000 scale unless otherwise specified.
- C. First discharge all capacitors. Carefully use a screwdriver to short from the connector shell, first to the "E" pin on 5-pin connector or "G" pin on 7-pin connector, then to all other pins.

4.3 ONE OUTPUT DOES NOT FIRE

- A. Replace circuit board assembly.

4.4 SYSTEM HAS WEAK OR NO OUTPUT

- A. Check stator (9) resistance - replace if defective - see section 5.0.
 - 1. Center pin to outer pin: 450-650 ohms (RX100 scale)
 - 2. Center pin to other outer pin: 5000-6000 ohms
 - 3. Center pin to lamination core: infinite

5.0 SERVICE - ALTERNATOR SECTION

- A. The unit breaks down into two major parts: the Alternator Section and the Back Cover Assembly. Remove the four back cover attaching screws (42), (44) and carefully pull the back cover assembly away from the alternator housing; unplug the 3-prong internal connector.
- B. The procedures of this section require the use of an arbor press.

5.1 DISASSEMBLY

- A. Remove the phenolic spacer (15), O-ring (14) and stator (9) from the alternator housing.
- B. -AW/-GVW UNITS ONLY: Remove hardware (16a), (16b), (16c) or (17a), (17b) and sleeve (18) from unit shaft.
- C. Drive spring pin (1a) out of coupling (1) and shaft and remove coupling.
- D. Remove screw (13), lockwasher (12), washer (11) and drive gear (10).
- E. If it is necessary to replace bearing-shaft (3), support the housing on the coupling end and press shaft out of the magnet-rotor assembly and housing.
- F. Wrap magnet-rotor assembly (7) in a cloth or paper to keep it clean.

5.2 PARTS REPLACEMENT

- A. Replace gasket (8).
- B. Replace coupling (1) and bearings (3) and (31a) with new parts.
- C. Replace any removed hardware with new parts.
- D. Aluminum housings should be cleaned with carbon tetrachloride or similar cleaning solution.
- E. Any metal filings should be cleaned from magnet-rotor (7) before reassembly.

5.3 REASSEMBLY-ALTERNATOR SECTION

- A. Press new bearing-shaft (3) into housing (4) until it bottoms against shoulder. Housing (4) should be supported behind the internal shoulder with tool no. 506 101B. Push on the outer race of the bearing using tool 506 101A.
- B. Clean all debris from the magnet-rotor assembly (7).
- C. Slide magnet-rotor assembly (7) over shaft with plate facing out as shown below. Support the shaft on the coupling end using tool no. 506 102B and, using tool no. 506 102C, press magnet-rotor assembly (7) on the shaft 0.575" past the shoulder for the drive gear.
- D. Slide coupling (1) onto the shaft and secure with spring pin (1a) through the coupling and shaft.
- E. -AW/-GVW UNITS ONLY: Install sleeve (18) and engine gear. Secure with hardware (16a), (16b), (16c) or (17a), (17b) - see page 4.
- F. Inspect gear (10); replace if worn. Secure with new hardware (11), (12), and (13).
- G. Reinstall stator with leads at the 6 o'clock position, a new O-ring (14) and spacer (15).

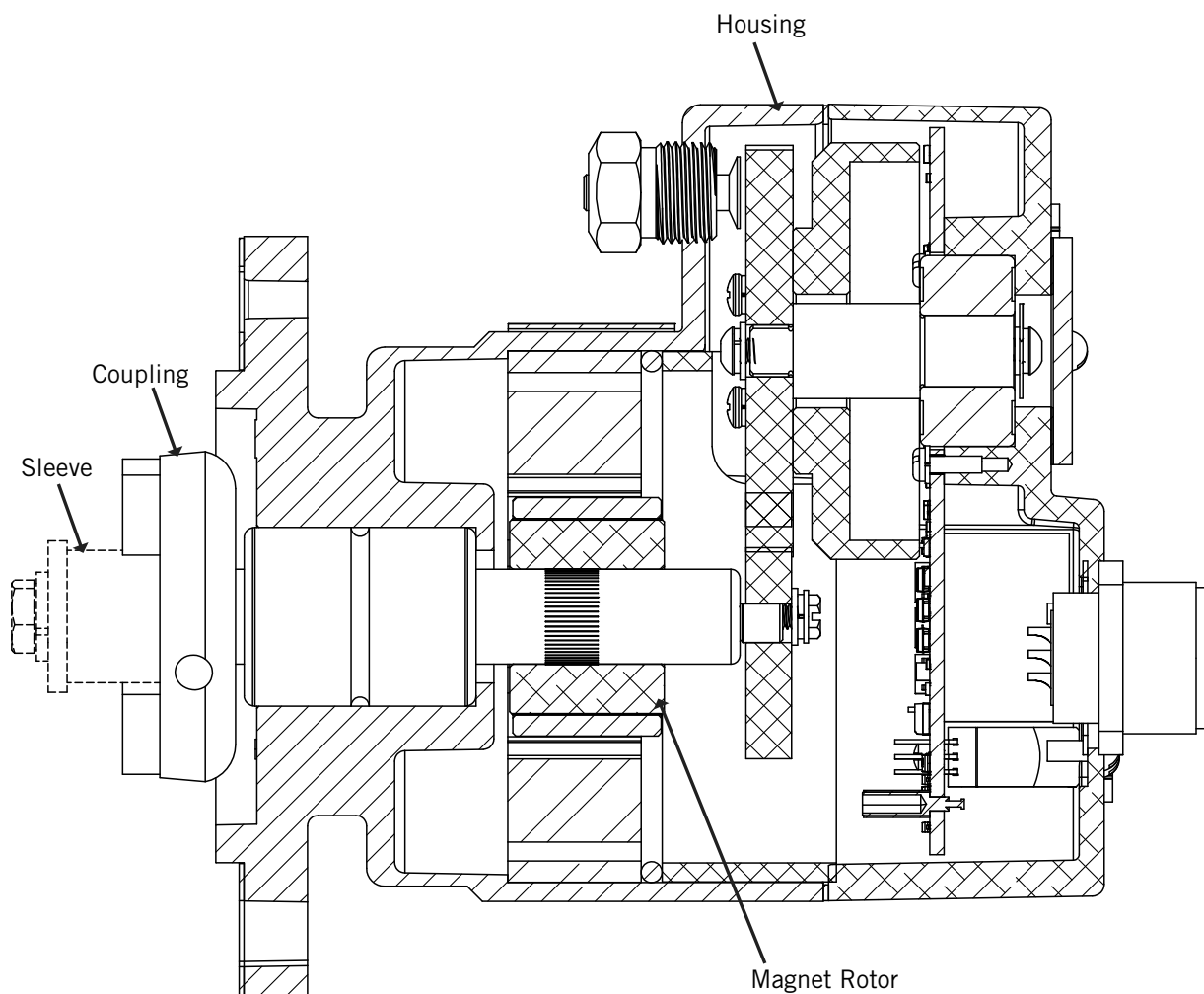

6.0 SERVICE – BACK COVER ASSEMBLY

Replace only those parts requiring service.

6.1 CIRCUIT BOARD ASSEMBLY (27) - REPLACEMENT

See page 6 for proper PCB number.

6.2 DRIVEN GEAR/MAGNET ARM ASSEMBLY (21)

Remove screw (19) and pull driven gear/magnet-arm assembly (21) from shaft (31b). DO NOT loosen the three small button-head, hex-socket screws holding the gear assembly together. Keep track of shim washers (47).

6.3 DRIVEN SHAFT (31b), BEARING (31a)

NOTE: It is recommended that all units be updated to the current design press fit secured driven shaft (31b).

- A. The procedures of this section require the use of a small arbor press.
- B. Remove the driven gear assembly (21) per section 6.3.
- C. Unplug the pickup coil connectors - see step 6.1A.
- D. Remove three screws (25) and lockwashers (20). Then pull the entire pickup plate assembly (26) off bearing (31a).
- E. Remove cover plate (39) and timing decal (37).
 - SNAP-RING SECURED DRIVEN SHAFT - Remove snap ring and pull driven shaft assembly from bearing (31a).
 - PRESS-FIT SECURED DRIVEN SHAFT - Press shaft (31b) out of bearing (31a).
- F. Press bearing (31a) out of rear housing (31).
- G. Support housing (31) with tool 506 103B; slide bearing (31a) over guide of tool no. 506 103B and press bearing into housing with tool no. 506 103A until it bottoms.
- H. Support bearing (31a) on the inner race with tool 506 104B and press, using tool 506 104A, on the gear shoulder of shaft (31b) until the shaft bottoms against bearing.

6.3.5 REASSEMBLY - DRIVEN SHAFT ASSEMBLY

- A. Install the V-NG circuitboard according to the UPGRADE instructions.
- B. Shims (47) on the end of the shaft may or may not be required under the Magnet Holder/Gear assembly.
- C. Check the air gap between the Magnet Holder and the accessible Hall-Effect components with a plastic feeler gauge. The proper gap is .020"-.030". If necessary add or remove shims to the end of the shaft to achieve the proper gap.
- D. Using a small brush, apply a thin coat of silicone compound (GC type 5Z; Altronic part no. 503259) to the teeth of the driven gear.
- E. Install washer (35), timing decal (37), lockwasher (12) and screw (19) but tighten so that the lockwasher just starts to compress.
- F. Place the magnet holder/gears magnet aligned with the "A" Hall-Effect (Top-Vertical). The red mark on the decal (37) should be placed to align with the single red mark on the label. Tighten screw (19).
- G. Install cover plate (39) and secure with two screws (0).

6.4 REASSEMBLY - BACK COVER TO ALTERNATOR SECTION

- A. Set the back cover assembly with the timing mark aligned to the single red timing mark in the top vertical position. Set the alternator coupling angle as shown in the chart below.
- B. Mate the back cover to the alternator keeping the alignment of the back cover timing mark and alternator coupling as set in step 6.6A.
- C. Secure the back cover to the alternator keeping the alignment of the back cover timing mark to the alternator with hardware (41), (42) and (44).

UNIT NO.	COUPLING ANGLE	
	CCW	CW
2A14-A, GV	0°	70°
2A14-AW, GVW	-	70°
2A14-D	-	0°
2A14-GV	-	70°
3A14-A, GV	0°	70°
3A14-D	-	0°
3A64-A, GV	0°	70°
3A64-AM	-	45°
3A64-AW, GVW	-	70°
4A24-A, GV	0°	70°
4A24-AW, GVW	-	70°
4A24-D	-	0°
4A34-A	0°	-
4A34-GVW	-	70°
5A24-GV	0°	-
6A24-D	-	0°
6A24-GV	0°	-
6A34-A, GV	0°	70°
6A34-AM	-	45°
6A34-AW, GVW	-	70°
6A34-GVC	-	70°

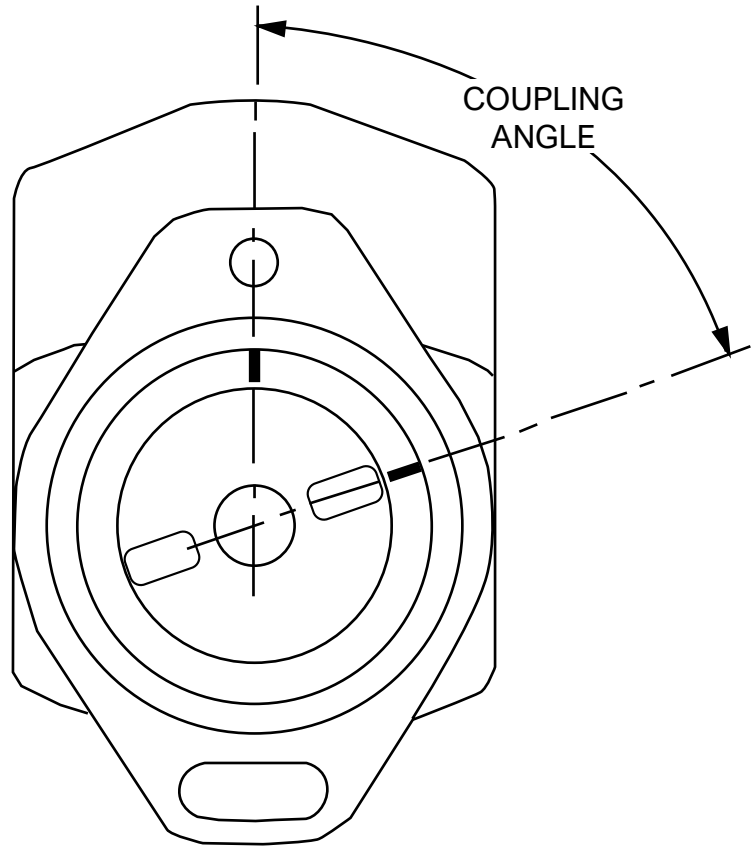

7.0 SERVICE – ASSEMBLY TOOLS

The following assembly tools are referenced in sections 5.3, and 6.4:

- 506101A Press bearing-shaft (3) into housing (4)
- 506101B Support housing (4)
- 506102B Support shaft (3)
- 506102C Press magnet-rotor assembly (7) on bearing-shaft (3)
- 506103A Press bearing (31a) into cover housing (31)
- 506103B Support cover housing (31) and bearing (31a)
- 506104A Press shaft (31b) into bearing (31a)
- 506104B Support bearing (31b)

8.0 OPERATIONAL TEST

- A. Perform the tests following the guidelines in sections 3.0 through 3.3.
- B. Run the Operating Test in section 3.2B for one hour.
- C. After the one-hour Operating Test, check timing per section 3.3